

PR
electronics



2255

f/i - f/f converter

No. 2255V102-UK

From ser. no. 980431001



EAC

CE

- DK** ▶ PR electronics A/S tilbyder et bredt program af analoge og digitale signalbehandlingsmoduler til industriel automation. Programmet består af Isolatorer, Displays, Ex-barrierer, Temperaturtransmittere, Universaltransmittere mfl. Vi har modulerne, du kan stole på i selv barske miljøer med elektrisk støj, vibrationer og temperaturudsving, og alle produkter opfylder de strengeste internationale standarder. Vores motto »Signals the Best« er indbegrebet af denne filosofi - og din garanti for kvalitet.
- UK** ▶ PR electronics A/S offers a wide range of analog and digital signal conditioning devices for industrial automation. The product range includes Isolators, Displays, Ex Interfaces, Temperature Transmitters, and Multifunctional Devices. You can trust our products in the most extreme environments with electrical noise, vibrations and temperature fluctuations, and all products comply with the most exacting international standards. »Signals the Best« is the epitome of our philosophy - and your guarantee for quality.
- FR** ▶ PR electronics A/S offre une large gamme de produits pour le traitement des signaux analogiques et numériques dans tous les domaines industriels. La gamme de produits s'étend des transmetteurs de température aux afficheurs, des isolateurs aux interfaces SI, jusqu'aux modules universels. Vous pouvez compter sur nos produits même dans les conditions d'utilisation sévères, p.ex. bruit électrique, vibrations et fluctuations de température. Tous nos produits sont conformes aux normes internationales les plus strictes. Notre devise »SIGNALS the BEST« c'est notre ligne de conduite - et pour vous l'assurance de la meilleure qualité.
- DE** ▶ PR electronics A/S verfügt über ein breites Produktprogramm an analogen und digitalen Signalverarbeitungsgeräte für die industrielle Automatisierung. Dieses Programm umfasst Displays, Temperaturtransmitter, Ex- und galvanische Signaltrenner, und Universalgeräte. Sie können unsere Geräte auch unter extremen Einsatzbedingungen wie elektrisches Rauschen, Erschütterungen und Temperaturschwingungen vertrauen, und alle Produkte von PR electronics werden in Übereinstimmung mit den strengsten internationalen Normen produziert. »Signals the Best« ist Ihre Garantie für Qualität!

f/i - f/f CONVERTER

TYPE 2255

CONTENTS

| | |
|---|----|
| Warning..... | 2 |
| Symbol identification | 3 |
| Safety instructions..... | 3 |
| How to dismantle system 2200..... | 5 |
| General..... | 6 |
| Technical characteristics..... | 6 |
| Input..... | 6 |
| Auxiliary supplies | 6 |
| Output(s)..... | 7 |
| Status indication | 7 |
| Electrical specifications..... | 8 |
| Order | 11 |
| Analogue output programming by way of jumpers..... | 11 |
| Block diagram..... | 12 |
| Programming / operating the function keys | 13 |
| Routing diagram: f/i converter with analogue and digital output..... | 14 |
| Setting of f/i converter with analogue and digital output.... | 16 |
| Routing diagram: f/f converter for pulse | 20 |
| Setting of f/f converter to pulse division / multiplication..... | 22 |
| Routing diagram: Frequency generator..... | 24 |
| Setting of frequency generator..... | 26 |



GENERAL

WARNING

This device is designed for connection to hazardous electric voltages. Ignoring this warning can result in severe personal injury or mechanical damage.

To avoid the risk of electric shock and fire, the safety instructions of this manual must be observed and the guidelines followed. The electrical specifications must not be exceeded, and the device must only be applied as described in the following.

Prior to the commissioning of the device, this manual must be examined carefully.

Only qualified personnel (technicians) should install this device.

If the equipment is used in a manner not specified by the manufacturer, the protection provided by the equipment may be impaired.



**HAZARDOUS
VOLTAGE**

WARNING

Until the device is fixed, do not connect hazardous voltages to the device. The following operations should only be carried out on a disconnected device and under ESD safe conditions:

Dismantlement of the device for setting of dipswitches and jumpers.

General mounting, connection and disconnection of wires.

Troubleshooting the device.

Repair of the device and replacement of circuit breakers must be done by PR electronics A/S only.



**INSTALL-
LATION**

WARNING

To keep the safety distances, devices with two built-in relays must not be connected to both hazardous and non-hazardous voltages on the same device's relay contacts.

SYSTEM 2200 must be mounted in socket type S3B Releco (order no 7023).

SYMBOL IDENTIFICATION



Triangle with an exclamation mark: Warning / demand.
Potentially lethal situations.



The CE mark proves the compliance of the device with the requirements of the directives.



The double insulation symbol shows that the device is protected by double or reinforced insulation.

SAFETY INSTRUCTIONS

DEFINITIONS

Hazardous voltages have been defined as the ranges 75...1500 Volt DC, and 50...1000 Volt AC.

Technicians are qualified persons educated or trained to mount, operate, and also troubleshoot technically correct and in accordance with safety regulations.

Operators, being familiar with the contents of this manual, adjust and operate the knobs or potentiometers during normal operation.

RECEIPT AND UNPACKING

Unpack the device without damaging it. The packing should always follow the device until this has been permanently mounted. Check at the receipt of the device whether the type corresponds to the one ordered.

ENVIRONMENT

Avoid direct sunlight, dust, high temperatures, mechanical vibrations and shock, as well as rain and heavy moisture. If necessary, heating in excess of the stated limits for ambient temperatures should be avoided by way of ventilation. All devices fall under Installation Category II, Pollution Degree 1, and Insulation Class II.

MOUNTING

Only technicians who are familiar with the technical terms, warnings, and instructions in the manual and who are able to follow these should connect the device.

Should there be any doubt as to the correct handling of the device, please contact your local distributor or, alternatively

PR electronics A/S
www.prelectronics.com

Mounting and connection of the device should comply with national legislation for mounting of electric materials, i.a. wire cross section, protective fuse, and location. Descriptions of Input / Output and supply connections are shown in the block diagram and side label.

The following apply to fixed hazardous voltages-connected devices:

The max. size of the protective fuse is 10 A and, together with a power switch, it should be easily accessible and close to the device. The power switch should be marked with a label telling it will switch off the voltage to the device.

CALIBRATION AND ADJUSTMENT

During calibration and adjustment, the measuring and connection of external voltages must be carried out according to the specifications of this manual.

The technician must use tools and instruments that are safe to use.

NORMAL OPERATION

Operators are only allowed to adjust and operate devices that are safely fixed in panels, etc., thus avoiding the danger of personal injury and damage. This means there is no electrical shock hazard, and the device is easily accessible.

CLEANING

When disconnected, the device may be cleaned with a cloth moistened with distilled water.

LIABILITY

To the extent the instructions in this manual are not strictly observed, the customer cannot advance a demand against PR electronics A/S that would otherwise exist according to the concluded sales agreement.

HOW TO DISMANTLE SYSTEM 2200

The back panel of the device is detached from the housing by way of a screw-driver as shown in picture 1

On a device with knobs, these must be removed before the PCB can be taken out as shown in picture 2.

After this, the back panel can be pulled out together with the PCB, but please notice the position of the PCB as there is a number of different positions in the house. Do not pull the wires unnecessarily, instead pull the PCB, see picture 3.

Switches and jumpers can now be moved. When assembling the back plate and housing, please make sure no wires are stuck.

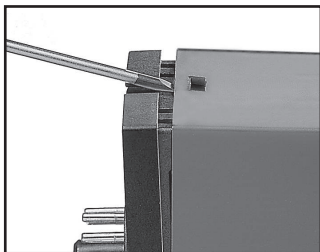

Picture 1: Dismantlement of back plate and housing.



Picture 2: Removal of knobs.

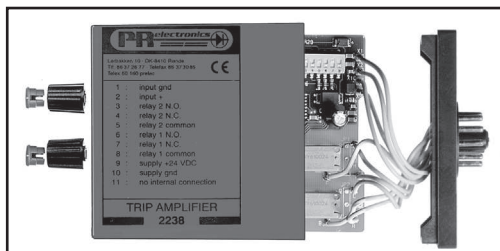

Picture 3: Removal of PCBs for adjustment of DIP-switches and replacement of jumpers.

f/I - f/f CONVERTER 2255

- Programmable f/I converter
- Programmable decimal divider / decimal multiplier
- Programmable frequency generator
- Relay output as option
- Supply voltage 24 VDC

General

The 2255 f/I - f/f converter is configured to the requested function by means of a menu-driven dialogue with keys and display in the front. Typical signalling device may be pulse generators e.g. flow meters, tacho-generators or inductive sensors.

The f/I function is used for frequency to current / voltage conversion within the frequency range from 0.001 Hz to 20 kHz and for speed control with the digital output as frequency watch.

The f/f function is used for division or multiplication of pulses and as a buffer for fast pulse trains.

Max. input frequency 20 kHz.

Max. output frequency 1 kHz.

The frequency generator function is for instance used as a time base or a clock generator. Max. output frequency 20 kHz. The 2255 can be delivered pre-configured according to specifications.

Technical characteristics

Input

Programmable input for connexion of standard pulse generator. Input filter may be selected for pulse width > 0.02 ms/max. 20 kHz, or > 10 ms/max. 50 Hz. By contact input, the filter for 10 ms/50 Hz should be used.

Auxiliary supplies

(selected by input configuration)

NAMUR supply:

8 VDC ± 0.5 V / 8 mA for supply of NAMUR sensors.

50 Supply:

15 VDC. I_{max}. 25 mA. I_{min}. (800 Ω load) 10 mA.

Special supply:

As option special voltage supplies within the range 5...15 VDC / 30 mA.

Output(s)

Standard current output (pin 3) programmable within the range 0...20 mA.

Min. span 5 mA. Max. span 20 mA.

Max. offset of 50% of the max. value.

Current limit: Max. 26 mA.

Standard voltage output (pin 2) is obtained by leading the current signal through an internal shunt resistor.

With internal dipoles a 50 Ω or a 500 Ω shunt resistor is selected, which results in a voltage output of 0...250 mV and 0 / 0.2...1 V (50 Ω) and 0...2.5 V and 0 / 2...10 V (500 Ω).

With a special internal shunt resistor, units with other output voltages can be delivered (max. 12 VDC).

Current and voltage signals are referring to the supply gnd. but if both signals are used simultaneously, only the voltage signal has gnd. as reference.

NPN pulse output (option) for relay, electromechanical counter or equivalent load. The output is current-limited to 130 mA with a PTC resistor.

The relay output (option) with change-over contact. 300 VA, max. 150 VRMS, 2 A. Max. DC load at 24 VDC is 1 A.

Status indication

2255 is equipped with 3 status indicators in the front.

f in: Indicates active input (inactive by the NPN input).
Input frequencies > 50 Hz are shown by fixed light.

Dig. out: Indicates active output.

Error: Indicates sensor error by NAMUR input.

Electrical specifications

Specifications range -20°C to +60°C

Common specifications:

Supply voltage 19.2...28.8 VDC
Internal consumption 2.4 W
Isolation, test / operation 1400 VAC / 150 VAC
Warm-up time 1 min.
Signal / noise ratio Min. 60 dB
Signal dynamics, output 16 bit
Response time (programmable) 60 ms to 999 s + period time

Calibration temperature 20...28°C
Temperature coefficient < $\pm 0.01\%$ of span / °C
Linearity error $\leq \pm 0.1\%$ of span
Effect of supply voltage change < 0.005% of span / VDC

Auxiliary voltages:

NAMUR supply 8 VDC ± 0.5 VDC / 8 mA
SO supply 15 VDC / 25 mA
Special (acc. to order) 5...15 VDC / 30 mA

Immunity influence < $\pm 0.5\%$

Air humidity < 95% RH (non-cond.)
Dimensions (HxWxD) 80.5 x 35.5 x 84.5 mm
Protection degree IP50
Weight 125 g

Input:

General:

Measurement range 0...20 kHz
Min. measurement range 0.001 Hz
Low cut off 0.001 Hz
Max. offset 90% of selec. max. value
Min. pulse width 25 μ s

NAMUR input:

| | |
|-----------------------|----------|
| Trig-level LOW | ≤ 1.2 mA |
| Trig-level HIGH..... | ≥ 2.1 mA |
| Input impedance | 1000 Ω |

Sensor error detection:

| | |
|---------------------|----------|
| Short-circuit | ≥ 7.0 mA |
| Breakage | ≤ 0.2 mA |
| Response time | ≤ 400 ms |

Tacho input:

| | |
|--------------------------|-----------|
| Trig-level LOW | ≤ 100 mV |
| Trig-level HIGH..... | ≥ 200 mV |
| Input impedance | ≥ 100 kΩ |
| Max. input voltage | 80 VAC pp |

NPN / PNP input:

| | |
|-----------------------|--------------|
| Trig-level LOW | ≤ 4.0 V |
| Trig-level HIGH..... | ≥ 7.0 V |
| Input impedance | Typ. 3.48 kΩ |

TTL input:

| | |
|-----------------------|-----------|
| Trig-level LOW | ≤ 1.2 VDC |
| Trig-level HIGH..... | ≥ 1.7 VDC |
| Input impedance | 100 kΩ |

S0 input:

| | |
|-----------------------|----------|
| Trig-level LOW | ≤ 4.5 mA |
| Trig-level HIGH | ≤ 6.2 mA |

Analog output:**Current output:**

| | |
|------------------------|--------------------------|
| Signal range | 0...20 mA |
| Min. signal range..... | 5 mA |
| Max. offset | 50% of selec. max. value |
| Updating time | 20 ms |
| Load (max.)..... | 20 mA / 600 Ω / 12 VDC |
| Load stability | < ±0.01% of span/100 Ω |

Voltage output through internal shunt:

| | |
|------------------------|--------------------------|
| Signal range | 0...10 VDC |
| Min. signal range..... | 250 mV |
| Max. offset | 50% of selec. max. value |
| Load (min.)..... | 500 k Ω |

NPN output:

| | |
|--------------------|--------|
| Max. current..... | 130 mA |
| Max. voltage | 28 VDC |

f/f converter output:

| | |
|-----------------------|-------------|
| Signal range | 0...1000 Hz |
| Min. pulse width..... | 500 μ s |
| Max. pulse width..... | 999 ms |
| Max. duty cycle..... | 50% |

Frequency generator:

| | |
|----------------------|------------------------|
| Pulse width | |
| f < 50 Hz | Min. 10 ms, max. 999 s |
| f \geq 50 Hz | 50% duty cycle |

Relay output:

| | |
|--------------------------|----------|
| Max. frequency | 20 Hz |
| Max. voltage | 150 VRMS |
| Max. AC current | 2 A |
| Max. AC power | 300 VA |
| Max. load at 24 VDC..... | 1 A |

Observed authority requirements:

| | |
|-------------------------|------------|
| EMC 2004/108/EC | EN 61326-1 |
| LVD 2006/95/EC..... | EN 61010-1 |
| EAC TR-CU 020/2011..... | EN 61326-1 |

Standard:

Of span = Of the presently selected range

Order

| Type | Version | Output |
|------|------------------|--|
| 2255 | Programmable : B | Analogue + NPN output : 1 Analogue + relay output : 2 |

Analogue output programming by way of jumpers

| Output range | JP3 | JP2 | JP1 |
|---|--------------|-----|-----|
| 0...10 mA (current only) | OFF | - | - |
| 0...20 mA (current only) | ON | - | - |
| 0...10 mA / 0...0.5 V | OFF | OFF | ON |
| 0...20 mA / 0...1.0 V | ON | OFF | ON |
| 0...10 mA / 0...5.0 V | OFF | ON | OFF |
| 0...20 mA / 0...10.0 V | ON | ON | OFF |
| Special voltage output: (Resistor R38 mounted) | ON or OFF | OFF | OFF |

BLOCK DIAGRAM

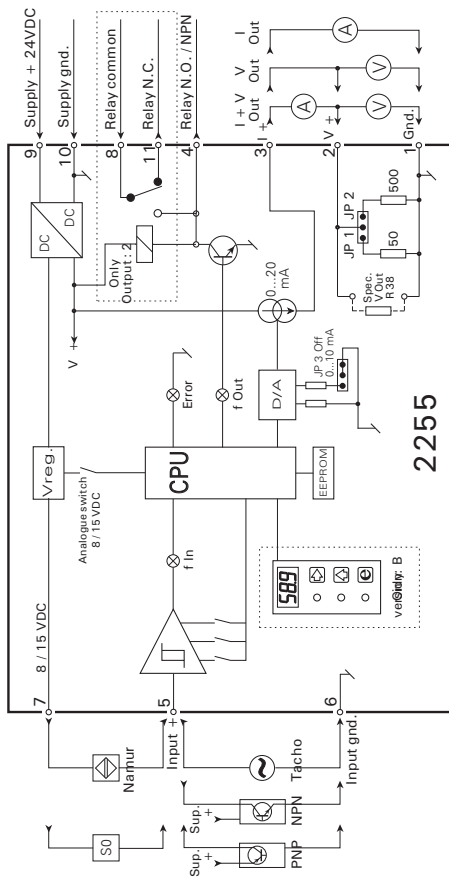

PROGRAMMING / OPERATING THE FUNCTION KEYS

DOCUMENTATION FOR ROUTING DIAGRAM

GENERAL:

The programming is menu-controlled. The main menus are numbered in level 0 (x.0), and the submenus are numbered in level 1 (x.1 to x.5). Each submenu has an accompanying entry menu. The menus are structured in such a way that the menus most frequently used are closer to the default menu 0.0. Please note that programming is only possible when submenu 5.4 PAS has the value 040.

Submenus and branches are selected by the 3 function keys **▶**, **▲** and **◀** as outlined in the routing diagram.

Activating **◀** in the branches will display the current value of the entry and parameter selection menus.

In entry menus, the digit that can be changed will flash.

Active digit position is shifted by the **▶** key, and the value is changed by the **▲** key.

When the decimal point flashes, its position can be changed by the **▶** key. In parameter selection menus you switch between the parameters by the **▲** key.

Save by first activating **▶** and then **▲** simultaneously.

Leave the entry menu without saving, activate **◀**.

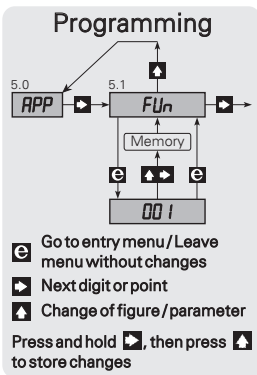

Routing diagram

for

f / I converter with analogue and digital output [Function no. 001]

At power ON, or if no keys have been activated for a period of 2 minutes, the display returns to main menu 0.0

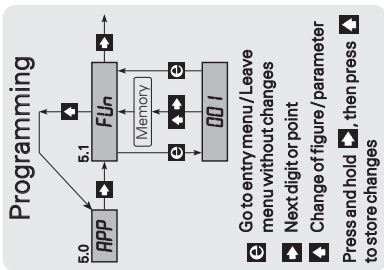
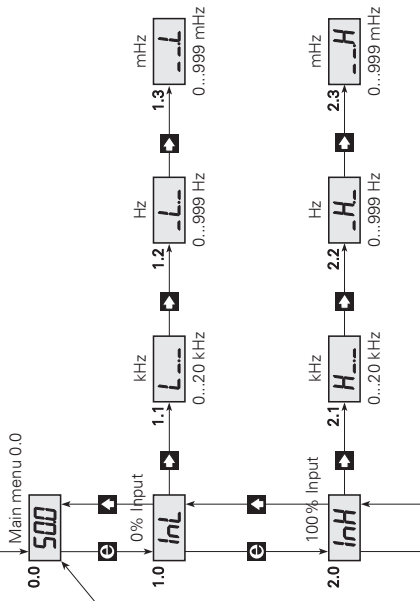

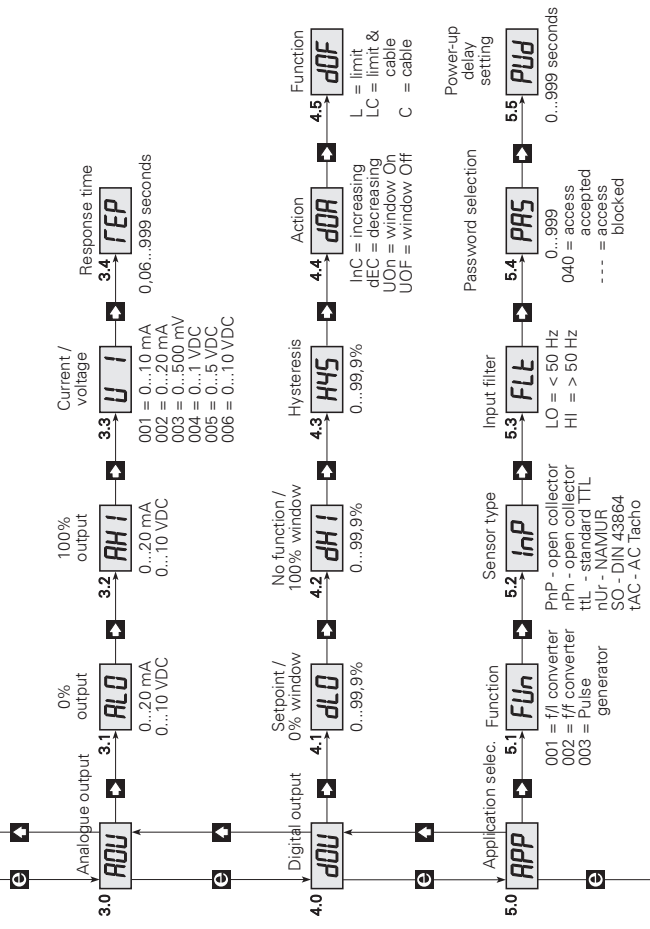

SETTING OF f/I CONVERTER WITH ANALOGUE AND DIGITAL OUTPUT

The following describes the routing diagram menu points from 0.0 to 5.5 for setting the f/I converter with analogue and digital output.

EXAMPLE:

Frequency span0...12550.5 Hz
Analogue output4...20 mA
Response time2.5 s
Alarm frequencies < 1000 Hz, > 11000 Hz (alarm window)
Hysteresis20 Hz
Digital output actionActive within the alarm window
Digital output function.....Trip amplifier and sensor fault alarm
Sensor.....NAMUR
Input filter.....Pulse width > 0.02 ms
Digital output power up delay.....10.0 s
First, the function f/I converter must be chosen in submenu 5.1.

0.0 DEFAULT - The input frequency is displayed in % of the input span.

At power ON, or if no keys have been activated for a period of 2 minutes, the display returns to default. When the display is in default, menu 0.0 activating the key  will indicate the present function, i.a. F01.

1.0 InL - Setting of 0% frequency.

1.1 L.- 0% setting of frequency in kHz.

Entering of example = 000.
Valid selections are 0...20.0 kHz.

1.2 -L- 0% setting of frequency in Hz.

Entering of example = 000.
Valid selections are 0...999 Hz.

1.3 -L 0% setting of frequency in mHz.

Entering of example = 000.
Valid selections are 0...999 mHz.

2.0 InH - Setting of 100% frequency.

2.1 H.- 100% setting of frequency in kHz.

Entering of example = 012.

Valid selections are 0...20.0 kHz.

2.2 -H.- 100% setting of frequency in Hz.

Entering of example = 550.

Valid selections are 0...999 Hz.

2.3 -H 100% setting of frequency in mHz.

Entering of example = 500.

Valid selections are 0...999 mHz.

3.0 AOU - Setting of analogue output.

3.1 ALO - 0% setting of analogue output

Entering of example = 04.0.

Valid selections are current 0.0...20.0 mA or voltage 0.0...10 VDC.

3.2 AHI - 100% setting of analogue output

Entering of example = 20.0.

Valid selections are current 0.0...20.0 mA or voltage 0.0...10 VDC.

3.3 UI - Current or voltage output setting

NB: Please see **jumper positioning** in "Programming of analogue output".

Entering of example = 002.

Possible selections are:

001 = current output 0...10 mA

002 = current output 0...20 mA (i.a. 4...20mA)

003 = voltage output 0...500 mV

004 = voltage output 0...1 V (i.a. 0.2...1 V)

005 = voltage output 0...5 V

006 = voltage output 0...10 V

3.4 rEP - Response time setting

If the selected response time < 0.06 s, the response time will be 0.06 seconds plus the input frequency response time. The response time will also act on the digital output so that the output will not activate / deactivate because of short-lived changes in the input frequency.

Entering of example = 02.5.

Valid selections are 0.06...999 seconds.

4.0 dOU - Digital setting of output

4.1 dLO - Setting of setpoint / limit frequency in % of the frequency span.

This value corresponds to the setpoint, when menu 4.4 dOA = { InC or dEC }, and it corresponds to the low limit frequency of a setpoint window when menu 4.4 dOA = { UOn or UOF }.

Entering of example = 7.97 (1000 / 12550.5 * 100 [%]).

Valid selections are 0.0...99.9%.

4.2 dHI - setting of limit frequency in % of the frequency span.

This value corresponds to the high limit frequency of a setpoint window and is only valid when menu 4.4 dOA = { UOn or UOF }.

Entering of example = 87.6 (11000 / 12550.5 * 100 [%]).

Valid selections are 0.0...99.9%.

4.3 HYS - Setting of hysteresis in % of the frequency span.

If 4.4 dOA = { UOn or UOF } the hysteresis is outside the window (4.1 and 4.2)

If 4.4 dOA = { InC } the hysteresis is below setpoint (4.1).

If 4.4 dOA = { dEC } the hysteresis is above setpoint (4.1).

Entering of example = 0.16 (20 / 12550.5 * 100 [%]).

Valid selections are 0.0...99.9%.

4.4 dOA - Digital output action setting.

For InC or dEC the digital output action will respectively be increasing or decreasing. The setpoint and the hysteresis must be set in menu 4.1 and 4.3.

For UOn the digital output is activated within the window.

For UOF the digital output is activated outside the window.

The low and the high limit frequency in the window are set in menu 4.1 and 4.2 respectively, and the hysteresis is set in menu 4.3.

Entering of example = UOn.

Possible selections are InC, dEC, UOn or UOF.

4.5 dOF - Digital output function setting.

If L (Limit) is selected, the digital output will work as a trip amplifier.

If LC (Limit, Cable) is selected, the digital output will act as both a trip amplifier and as a sensor error monitor. If C (Cable) is selected, the digital output will act as a sensor error monitor.

Sensor error monitoring is performed only by NAMUR sensor when submenu 5.2 InP = nUr

Entering of example = LC.

Possible selections are L, LC or C.

5.0 APP - Application selection

5.1 FUn - Funktion selection.

On a function change, the unit resets and the display returns to default, menu 0.0.

Possible functions are:

001 = f/l converter

002 = f/f converter

003 = Frequency generator

Entering of example = 001.

Valid selections are 001, 002 and 003

5.2 InP - Sensor type selection.

PnP = PNP proximity switch open collector or switch to +24 VDC.

nPn = NPN proximity switch open collector or switch to Gnd.

tTl = TTL, standard TTL signals at 5 VDC level.

nUr = NAMUR in accordance with DIN 19234.

SO = SO interface in accordance with DIN 43864.

tAC = AC Tacho.

Entering of example = nUr.

Possible selections are: PnP, nPn, tTl, nUr, SO and tAC

5.3 FLt - Input filter setting.

On contact input the LO filter should be used to eliminate bounce input.

Entering of example = Hi.

Possible selections are LO - 50 Hz or HI - 20 kHz.

5.4 PAS - Password selection.

When the password is 040, changes may be made in all menu points.

When the password is <> 040, programming is locked in all menu points, but open for reading the value.

Entering of example = 040.

Valid selections are 0...999.

5.5 PUd - Power-up delay setting.

The power-up delay time is the period of time in which the digital output is out of function after power connection.

Entering of example = 10.0.

Valid selections are 0...999 seconds.

Routing diagram

for

f / f converter to multiplication / division [Function no. 002]

At power ON, or if no keys have been activated for a period of 2 minutes, the display returns to main menu 0.0

Power On

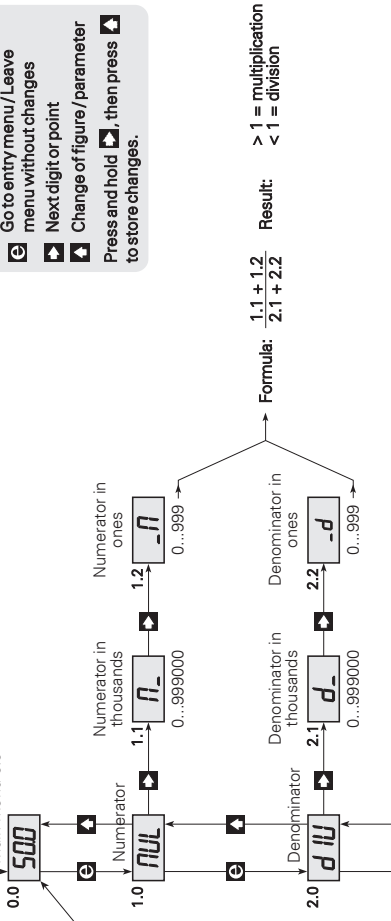

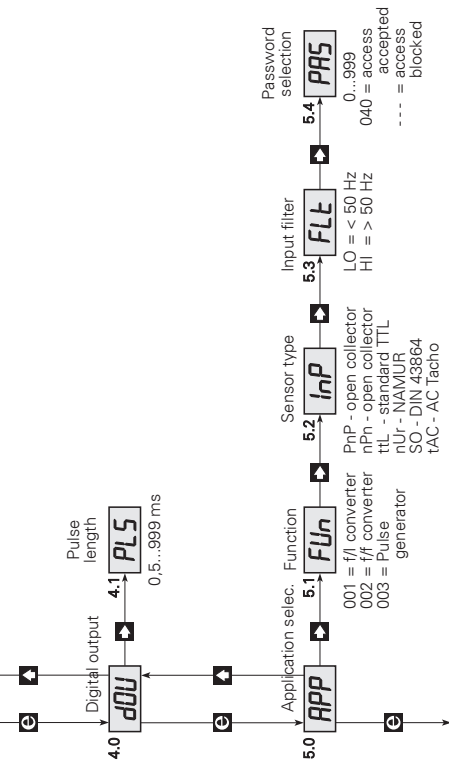

SETTING OF f/f CONVERTER TO PULSE DIVISION / MULTIPLICATION

The following describes the routing diagram menu points from 0.0 to 5.4 for setting the f/f converter. When the function is selected for f/f converter, the analogue output is disabled so that it assumes the value 0 mA.

EXAMPLE:

Sensor.....NAMUR

Output frequencyInput frequency divided by 6.75

Output pulse length500 ms

First, the function f/f converter must be chosen in submenu 5.1.

0.0 Default - The number of pulses in the buffer is displayed.

The display returns to default when power is switched ON, or if no keys are activated for a period of 2 minutes.

The pulse function is set as a fraction. The numerator is set in submenu 1.1 and 1.2, and the denominator is set in submenu 2.1 and 2.2. If for instance the input frequency must be multiplied by 10 the multiplier is set to 10 and the divisor is set to 1.

1.0 MUL - Setting the multiplier.

In submenu 1.1 og 1.2 the numerator is set to a value between 0 and 999999.

1.1 M- - Setting of multiplier in thousands.

Entering of example = 000

Valid selections are 0...999000

1.2 -M - Setting of multiplier in ones.

Entering of example = 100

Valid selections are 0...999

2.0 dIV - Setting the divisor.

In submenu 2.1 and 2.2 the denominator is set to a value between 0 and 999999.

2.1 d- - Setting of divisor in thousands.

Entering of example = 000

Valid selections are 0...999000

2.2 -d - Setting of divisor in ones.

Entering of example = 675

Valid selections are 0...999

4.0 dOU - Output pulse length setting

4.1 PLS - Setting of output pulse length in ms.

Entering of example = 500

Valid selections are 0.5...999 ms (max. 1000 Hz)

5.0 APP - Application selection.

5.1 FUn - Function selection.

On a function change, the unit resets and the display returns to default, menu 0.0.

Entering of example = 002

Possible selections are:

001 = f/l converter

002 = f/f converter

003 = Frequency generator

5.2 InP - Sensor type selection.

Entering of example = nUr

Possible selections are:

PnP = PNP proximity switch open collector or switch to +24 VDC.

nPn = NPN proximity switch open collector or switch to Gnd.

ttL = TTL, standard TTL signals on 5 VDC level.

nUr = NAMUR in accordance with DIN 19234.

SO = SO interface in accordance with DIN 43864.

tAC = AC Tacho.

5.3 FLt - Input filter setting.

LO filter should be used on the switch input to eliminate bounce.

Entering of example = HI

Possible selections are LO - 50Hz or HI - 20kHz.

5.4 PAS - Password selection.

When the password is 040, changes may be made in all menu points.

When the password is <> 040, programming is blocked in all menu points but open for reading the setting value.

Entering of example = 040.

Valid selections are 0...999.

Routing diagram

for

Frequency generator [Function no. 003]

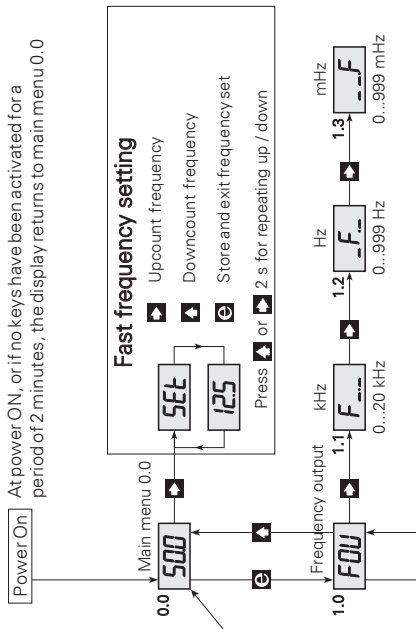
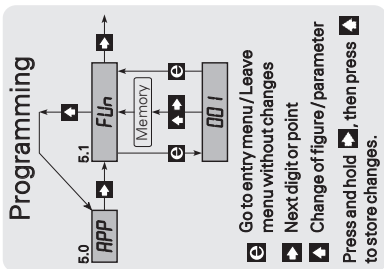

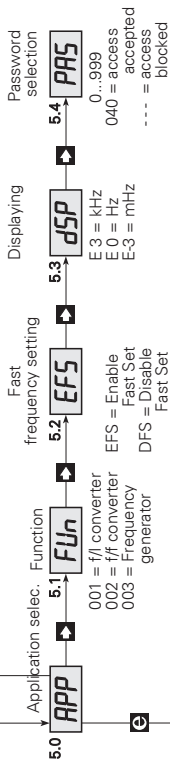
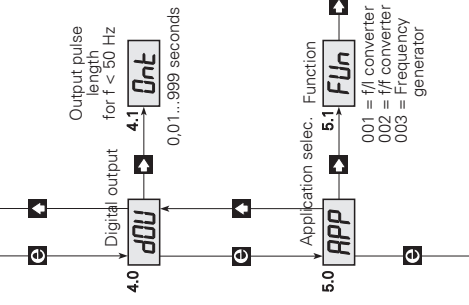

SETTING OF FREQUENCY GENERATOR

The following describes the routing diagram menu points from 0.0 to 5.4 for setting as a frequency generator. When the function is selected as a frequency generator, the analogue output is disabled.

EXAMPLE:

Output frequency12550.5 Hz
Fast change of frequencyPossible
Displayingin kHz
First, the function frequency generator must be chosen in submenu 5.1.

0.0 Default - The output frequency in kHz, Hz or mHz is displayed.

The display returns to default when power is switched ON, or if no keys are pressed for a period of 2 minutes. Pressing **▼** will indicate the present function, i.a. F01.

▼ Fast setting - Shortcut key for changing output frequency

When submenu 5.2 has been selected for EFS - Enable Fast Setting -, fast frequency changing is possible with the Fast Setting function.

The function keys in this menu have a special function: **▲** counts the frequency up and **▼** counts the frequency down from the value it had when activated. **Ⓢ** stores the value; the output changes to the frequency displayed.

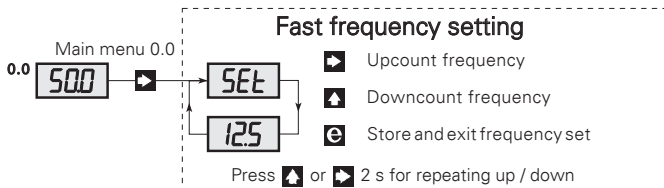

1.0 FOU - Output frequency setting

1.1 F.- - Setting of output frequency in kHz.

Entering of example = 012.

Valid selections are 0...20.0 kHz.

1.2 -F.- - Setting of output frequency in Hz.

Entering of example = 550.

Valid selections are 0...999 Hz.

1.3 -F - Setting of output frequency in mHz.

Entering of example = 500.

Valid selections are 0...999 mHz.

4.0 dOU - Output pulse length setting

4.1 Ont - Setting of output pulse length in s.

The pulse length can only be set for frequencies < 50 Hz, and an interval of minimum 10 ms between the pulses is always required. At frequencies of 50 Hz and above, the pulses have a 50% duty cycle.

Entering of example = 500.

Valid selections are 0.01...999 s.

5.0 APP - Application selection.

5.1 FUn - Function selection

On function change, the unit resets and the display returns to default, menu 0.0

Entering of example = 003

Possible selections are:

001 = f/l converter

002 = f/f converter

003 = Frequency generator.

5.2 EFS - Access setting for fast frequency changing.

Access to fast frequency changing is determined by the parameters EFS - Enable Fast setting, or dFS - Disable Fast setting.

Entering of example = EFS

Possible selections are EFS or dFS.

5.3 dSP - Default display units.

Entering of example = E 3

Possible selections are E 3 display in kHz, E 0 display in Hz or E-3 display in mHz.

5.4 PAS - Password selection.

When the password is 040, changes may be made in all menu points.

When the password is <> 040, the programming is blocked in all menu points but open for reading the value.

Entering of example = 040.

Valid selections are 0...999.



Displays

Programmable displays with a wide selection of inputs and outputs for display of temperature, volume and weight, etc. Feature linearization, scaling, and difference measurement functions for programming via PReset software.



Ex interfaces

Interfaces for analog and digital signals as well as HART® signals between sensors / I/P converters / frequency signals and control systems in Ex zone 0, 1 & 2 and for some devices in zone 20, 21 & 22.



Isolation

Galvanic isolators for analog and digital signals as well as HART® signals. A wide product range with both loop-powered and universal isolators featuring linearization, inversion, and scaling of output signals.



Temperature



























A wide selection of transmitters for DIN form B mounting and DIN rail devices with analog and digital bus communication ranging from application-specific to universal transmitters.



Universal

PC or front programmable devices with universal options for input, output and supply. This range offers a number of advanced features such as process calibration, linearization and auto-diagnosis.



-   www.preelectronics.fr
 sales-fr@preelectronics.com
-   www.preelectronics.de
 sales-de@preelectronics.com
-   www.preelectronics.es
 sales-es@preelectronics.com
-   www.preelectronics.it
 sales-it@preelectronics.com
-   www.preelectronics.se
 sales-se@preelectronics.com
-   www.preelectronics.com
 sales-uk@preelectronics.com
-   www.preelectronics.com
 sales-us@preelectronics.com
-   www.preelectronics.cn
 sales-cn@preelectronics.com
-   www.preelectronics.be
 sales-be@preelectronics.com

Head office

Denmark
PR electronics A/S
Lerbakken 10
DK-8410 Rønde

www.preelectronics.com
sales@preelectronics.dk
tel. +45 86 37 26 77
fax +45 86 37 30 85



QUALITY SYSTEM AND ENVIRONMENTAL MANAGEMENT SYSTEM
DS/EN ISO 9001
DS/EN ISO 14001

